

lounge esprit 6-695a

Hannes Wettstein, 2007

Sessel, Sitz mit Komfortpolsterung, Rücken
Formsperrholz, Polster vorne aufgesetzt, Füsse und
Rückenschwinge massiv gebogen, stapelbar
B59, T63, H75, SH41, ALH61

Hannes Wettstein, 2007

Siège, assise avec rembourrage confort, dossier en
contreplaqué moulé 3D, rembourré à l'avant, dossiers et
pieds en bois massif courbé, empilable
L59, P63, H75, HAss41, HAcc61

Hannes Wettstein, 2007

Chair, seat with comfort upholstery, moulded plywood
back, upholstered on the front, legs and rear cross-brace
solid bentwood, stackable
W59, D63, H75, SH41, ALH61

Varianten / variantes / variants

lounge
6-693lounge
6-693alounge
6-695lounge
6-675lounge
6-675a

Technische Angaben / specifications / specifications

Masse / mesure / measure

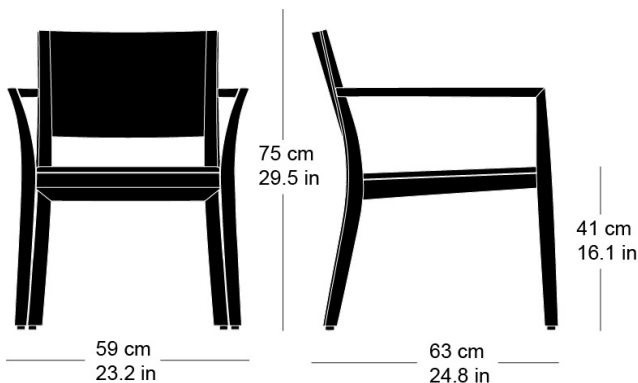

Gewicht / poids / weight 7.2 kg 14.4 lb

Polsterung / rembourrage /
upholstery ja / oui / yes

Stapelung / empilage / stacking 4 Stühle / chaises / chairs

lounge esprit 6-695a

Holzarten / types de bois / types of wood

Belag / revêtement / surface



Buche natur BN 000 AM
Beech natural BN 000 AM
Hêtre naturel BN 000 AM



Schwarznuss natur NN 000 AM
Black walnut natural NN 000 AM
Noyer noir naturel NN 000 AM



Eiche natur EN 000 AM
Oak natural EN 000 AM
Chêne naturel EN 000 AM



Buche schwarz BB 203 SG
Beech black BB 203 SG
Hêtre noir BB 203 SG



Esche natur FN 000 AM
Ash natural FN 000 AM
Frêne naturel FN 000 AM



Buche anthrazit BB 200 SG
Beech anthracite BB 200 SG
Hêtre anthracite BB 200 SG



Buche geweisst BG 172 SG
Beech whitewashed BG 172 SG
Hêtre teinté blanc BG 172 SG

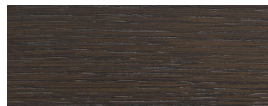

Eiche Räuchereiche EB 535 AM
Oak smoked oak EB 535 AM
Chêne chêne fumée EB 535 AM

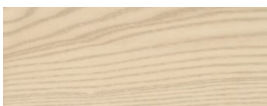

Esche weisspigmentiert FW 001 OL
Ash white-pigmented FW 001 OL
Frêne pigmenté blanc FW 001 OL

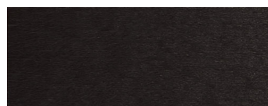

Buche Ebony BB 100 SG
Beech ebony BB 100 SG
Hêtre teinté ebony BB 100 SG

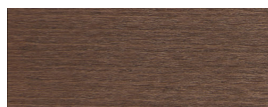

Buche Nuss BB 151 SG
Beech walnut BB 151 SG
Hêtre teinté noyer BB 151 SG



Esche schwarz FB 203 AM
Ash black FB 203 AM
Frêne noir FB 203 AM